

DOCUMENT RESUME

ED 059 227

TE 499 799

AUTHOR Dubocq, Edward R.
TITLE Sculpture: Creative Designs with Modern Materials
(Tentative Course Outline).
INSTITUTION Dade County Public Schools, Miami, Fla.
PUB DATE 71
NOTE 51p.; An Authorized Course of Instruction for the
Quinmester Program

EDRS PRICE MF-\$0.65 HC-\$3.29
DESCRIPTORS *Art Education; *Art Materials; *Creative Art;
*Sculpture; Student Attitudes; Teaching Techniques;
*Textiles Instruction; Vocabulary

ABSTRACT

This document reports on a course in comprehension and application of various techniques of sculpture and collage, using a contemporary point of view. Students will work with contemporary materials such as wood, metals, plaster, plastics, styrofoam, and many other cardboard basic materials suitable for creative design products. This unit will cover several of the most popular and widely used techniques in depth. Objects are: Students upon completion of this unit will be able to: (1) Describe procedures for wood, metal, plaster, styrofoam, plastic and fiberglass sculpting and base design and creation; (2) Define related vocabulary terms; (3) Differentiate among a minimum of four sculptors from past and/or contemporary movements that sculpt in modern materials; (4) Manipulate sculpting tools for modern materials; (5) Create open and closed forms in modern materials; (6) Compare and differentiate among various modern materials; (7) Practice the correct procedures for working in a sculpture studio; (8) Create a minimum of two sculptural examples, from the six types of media described; (9) Construct a compatible base for each of the two sculptures created; and (10) Demonstrate a professional artistic attitude towards materials, fellow students, and instructor during the course of this unit. Course content includes introduction, studio procedures and care, sculpture techniques, studio work, critique and evaluation. The procedure followed is a three dimensional design. (Author/CK)

ED 059227

U.S. DEPARTMENT OF HEALTH, EDUCATION & WELFARE
OFFICE OF EDUCATION

THIS DOCUMENT HAS BEEN REPRODUCED EXACTLY AS RECEIVED FROM THE PERSON OR ORGANIZATION ORIGINATING IT. POINTS OF VIEW OR OPINIONS STATED DO NOT NECESSARILY REPRESENT OFFICIAL OFFICE OF EDUCATION POSITION OR POLICY.

AUTHORIZED COURSE OF INSTRUCTION FOR THE **QUINMESTER PROGRAM**
**DADE COUNTY PUBLIC SCHOOLS**

CREATIVE DESIGNS WITH MODERN MATERIALS
(Tentative Course Outline)

SCULPTURE

6683.18

6681.17

6882.17

Art Education

"PERMISSION TO REPRODUCE THIS
COPYRIGHTED MATERIAL HAS BEEN GRANTED

BY DADE COUNTY PUBLIC
SCHOOLS

TO ERIC AND ORGANIZATIONS OPERATING
UNDER AGREEMENTS WITH THE U.S. OFFICE OF
EDUCATION. FURTHER REPRODUCTION OUTSIDE
THE ERIC SYSTEM REQUIRES PERMISSION OF
THE COPYRIGHT OWNER."

DIVISION OF INSTRUCTION • 1971

TE 499 799

SCULPTURE
CREATIVE DESIGNS WITH MODERN MATERIALS
(Tentative Course Outline)

6683.18

6681.17

6882.17

ART EDUCATION

Written by: Edward R. Dubocq

for the

DIVISION OF INSTRUCTION
Dade County Public Schools
Miami, Florida
1971

DADE COUNTY SCHOOL BOARD

Mr. William Lehman, Chairman
Mr. G. Holmes Braddock, Vice-Chairman
Mrs. Ethel Beckham
Mrs. Crutcher Harrison
Mrs. Anna Brenner Meyers
Dr. Ben Sheppard
Mr. William H. Turner

Dr. E. L. Whigham, Superintendent of Schools
Dade County Public Schools
Miami, Florida 33132

Published by the Dade County School Board

TABLE OF CONTENTS

I. COURSE TITLE.....1

II. COURSE NUMBERS.....1

III. COURSE DESCRIPTION.....1

IV. RATIONALE.....1

V. COURSE ENROLLMENT GUIDELINES.....2

VI. COURSE OF STUDY OBJECTIVES.....2

VII. COURSE CONTENT

 Introduction.....5

 Studio procedures and care.....5

 Sculpture techniques.....5

 Studio work.....5

 Critique and evaluation.....5

VIII. COURSE PROCEDURES AND STRATEGIES, AND
SUGGESTED LEARNING ACTIVITIES

 Procedure.....6

 Materials and supplies.....7

 Studio procedures for students.....11

 Hints for instructors.....12

 Work sheets

 Wood carving.....14

 Metal sculpture.....17

 Plaster sculpture.....24

 Styrofoam sculpture.....27

 Plastic sculpture.....30

Fiberglass sculpture.....34
Base design and creation.....38
IX. VOCABULARY.....40
X. RESOURCES
Books.....45
Movies.....45

I. COURSE TITLE

CREATIVE DESIGNS WITH MODERN MATERIALS

II. COURSE NUMBERS

6683.18

6681.17

6882.17

III. COURSE DESCRIPTION

Comprehension and application of various techniques of sculpture and collage, using a contemporary point of view. Students will work with contemporary materials such as wood, metals, plaster, plastics, styrofoam, and many other cardboard basic materials suitable for creative design products.

IV. RATIONALE

Sculpture: Plastic or hard materials that have been welded, carved, engraved, molded, or constructed into a primarily three-dimensional work of art. Students of art should become acquainted with the various areas of sculpture. We are constantly surrounded with varying forms of sculpture in our natural environment. Technically speaking, Sculpture can entail any three-dimensional form around us, from a tree, to a building. Sculpture,

in one way or another, affects every day of our lives; through an object that is pleasing to the eye, or the pure functionality of a unit of sculptured steel, the modern automobile.

Due to the scope of modern materials available to the artist today, this unit will cover only several of the most popular and widely used techniques in depth. It is recommended that the student should not be limited to these methods alone, but that he use them as a starting point from which to progress.

V. COURSE ENROLLMENT GUIDELINES

- A. Elective, exploratory
- B. No prerequisite for enrollment in this course, nor any concurrent course suggested.
- C. To prepare the student for more advanced techniques and courses in the area of Sculptural Art.
- D. Method: (By Week)
Lecture, demonstration, studio experimentation, critique.

VI. COURSE OF STUDY OBJECTIVES

- A. Competencies: The student upon completion of this unit will be able to:

1. Describe the procedures for the following sculpting techniques.
 - a. Wood sculpting
 - b. Metal sculpting
 - c. Plaster sculpting
 - d. Styrofoam sculpting
 - e. Plastic sculpting
 - f. Fiberglass sculpting
 - g. Base design and creation
2. Define, in writing, related vocabulary terms as listed in part IX of this quinmester course of study.
3. Differentiate among a minimum of four sculptors from past and/or contemporary movements that sculpt in modern materials.
4. Manipulate sculpting tools for modern materials, according to their specifications.
5. Create open and closed forms in modern materials through manipulation of related tools.
6. Compare and differentiate among various modern materials (fiberglass, plaster, plastic, etc.) and their potential use for sculpting.

7. Practice the correct procedures for working in a sculpture studio.
 8. Create a minimum of two sculptural examples from the six different types of media described.
 9. Construct a compatible base for each of the two sculptures created.
 10. Demonstrate a professional artistic attitude towards materials, fellow students and instructor during the course of this unit.
- B. The student will demonstrate competencies under the following conditions:
1. Classroom demonstration
 2. Classroom discussion
 3. Individual research
 4. Individual studio procedures
 5. Group critiques
- C. Acceptable performance will be determined by the individual instructor on the basis of --
1. Evaluation of classroom participation.
 2. Required projects turned in for grade.
 3. Empirical testing.
 4. Test items based on the ten performance objectives.

5. Final critique

VII. COURSE CONTENT

A. Introduction by means of any of the following:

1. Films and slides
2. Discussion
3. Lecture
4. Demonstration
5. Research
6. Resource materials

B. Studio procedures and care

1. Equipment
2. Tools
3. Studio
4. Storage

C. Sculpture techniques

1. Wood sculpture
2. Metal sculpture
3. Plaster sculpture
4. Styrofoam sculpture
5. Plastic sculpture
6. Fiberglass sculpture
7. Base design

D. Studio work

E. Critique and evaluation

VIII. COURSE PROCEDURES AND STRATEGIES, AND SUGGESTED LEARNING ACTIVITIES

A. Procedure:

(Suggested instructor demonstration aid)

The general procedures that apply to all forms of sculpture are discussed in this section. Individual procedures for specific sculptural techniques are described on the work sheets.

The primary guideline applying to all forms of sculpture is good three-dimensional design. In sculpture, the design must be related to a free standing form that will be viewed from all sides. You should keep this fact in mind when designing sketches or models. If a sculpture has been well designed, it will be pleasing to the eye from any angle.

As in painting or collage, the basic design should be developed through a series of thumbnail sketches or clay models. Develop an idea of what the sculpture will look like before beginning to sculpt. By doing a series of shape or form models, the student will discover certain forms that appeal to his/her artistic style.

Another factor to consider is the base or stand that will support the finished sculpture. It is easy to make the mistake of designing a base that detracts from the overall visual effect of the sculpture. When a base is used, it becomes a part of the sculpture. It should relate to the sculpture, and yet be subtle in its relationship.

In creating a sculpture, try to have the finished piece show movement. A piece of sculpture that appears to relate action or movement has a much greater visual impact than one that is stagnant or unmoving.

There are more specific steps and processes in the creation of modern material sculpture. They are outlined in the work sheets included in this quinmester course of study.

B. Materials and supplies

1. General materials:

- a. Rags
- b. Newspaper
- c. Pliers (assorted)
- d. Files (assorted)
- e. String

- f. Hammers
- g. Tin snips (assorted)
- h. Shears (metal and cloth)
- i. Brushes
- j. Jars or tin cans
- k. Steel drums (or working tables)
- l. Water source
- m. Masking tape
- n. Clamps
- o. Broom
- p. Protective clothing

2. Materials for specific areas:

a. Wood sculpture

- (1) Wood
- (2) Carving tools
- (3) Sandpaper
- (4) Hotplate
- (5) Dull lacquer
- (6) Fine steel wool
- (7) Glue (croid, scotch or epoxy)
- (8) Beeswax
- (9) Metal tin
- (10) Saucepan
- (11) Turpentine
- (12) Butchers wax

b. Metal sculpture (welding)

- (1) Metal
- (2) Welding table
- (3) Rods of flux
- (4) Welding goggles
- (5) Protective gloves
- (6) Anvil
- (7) Spring and adjustable clamps
- (8) Burnishing tools
- (9) Emery paper
- (10) Oxy-acetylene equipment
- (11) Wire brush
- (12) Miscellaneous patina chemicals
(see work sheet)

c. Plaster sculpture

- (1) Plaster
- (2) Carving tools (plaster)
- (3) Vermiculite
- (4) Wire screen or chicken wire
- (5) Water jars
- (6) Mixing containers
- (7) Rags
- (8) Burlap
- (9) Balloons
- (10) Coat hangers
- (11) 1/2 gallon milk cartons
- (12) Area for mixing (preferably outdoors)

d. Styrofoam sculpture

- (1) Styrofoam
- (2) Electric hot wire cutter
- (3) Lacquer thinner)
- (4) Acetone) one of these
- (5) Turpentine)
- (6) Epoxy glue
- (7) Asphalt emulsion adhesive
- (8) Sandpaper
- (9) Serrated knives
- (10) Coping saws
- (11) Adequate ventilation for
hot wire cutter

e. Plastic sculpture (Acrylic sheet)

- (1) Acrylic sheet
- (2) Soap
- (3) Electric jig saw
- (4) Coping saws
- (5) Electric burner or oven
- (6) Electric drill
- (7) Ethylene dichloride

f. Fiberglass sculpture

- (1) Polyester resin
- (2) Acetone (solvent)
- (3) Fiberglass cloth

- (4) Fiberglass mat
- (5) Roller
- (6) Sandpapers
- (7) Small squeeze bottle
- (8) Tin cans
- (9) Stirring sticks
- (10) Armature materials
- (11) Coloring agents
- (12) Fillers
- (13) Gel coat
- (14) Mek peroxide (hardener)

C. Studio procedures for students

(This list may be duplicated and distributed to individual students.)

1. Each student will be assigned an individual work and storage area for which he or she will be responsible.
2. Carving tools will be distributed on a sign-out basis. Students will be expected to demonstrate correct care for and use of carving tools.
3. At no time will any student be allowed to use, touch or move another students' materials or project.

4. Monitors will be assigned by the instructor to supervise certain areas.
5. Students will at all times be expected to maintain a professional, artistic attitude towards their materials, fellow students, and instructor.

D. Hints for instructors

1. Due to the vast diversification of techniques employed in this unit, it is strongly recommended that the instructor set aside a clearly defined area in the studio for each process. (This will avoid contamination of media).
2. There are many visual aids available in this area. Plan the ordering of movies, slides, etc. well in advance.
3. Design the studio so that there is a specific area or rack to store all supplies and equipment. This makes for an excellent way of getting a quick check of materials at the end of each period.

4. Assign monitor positions, on a rotating basis.
5. If tools are at a premium have students sign them out.
6. Have the monitors supervise cleanup areas at the end of each period.
7. Many processes and techniques covered in this unit are explored in depth as individual quinmester courses. These in-depth quinmester courses are listed in "References for Instructors" and also where applicable on the work sheets in this outline.
8. Please try to promote completely free, and yet safe artistic expression. (Both qualities are needed in a good artist).

E. Work sheets

Note: The following work sheets have been designed as direct reaching aids for the students use. They may be duplicated and distributed to the students for reference following the instructor's demonstrations.

Work Sheet # 1 - Modern Materials

Wood Carving

The first step in this process is to select the piece of wood you wish to carve. There are literally hundreds of types to choose from. The best method is to take your chisel and work the surface of different types to find one that suits your taste. You should also refer to existing finished wood sculptures to see how the piece "finishes out."

Once you have selected the wood, observe it closely. See if there are any interesting shapes suggested in the piece. You may be able to incorporate these shapes into your design. Brace the piece securely to the bench with a bench clamp.

Begin to carve, cutting across the grain of the wood, removing relatively small chips. Work slowly, turning the piece frequently and carving from all sides. Step back from the piece occasionally and observe it, checking for proper proportion, etc.

Once you have achieved the "rough" shape of the piece, (to within 1/2" of the finished surface), you are ready to begin surface treatment.

There are two basic types of surface treatment in wood. One is a rough, textured surface; the other, sanded, rubbed, and polished. A rough, tooled surface gives a very interesting effect. A highly polished surface brings out the colors and grain patterns in the wood. The final choice is up to the individual artist. Some sculptors combine both qualities in one piece.

The procedure for a smoothest texture possible with the chisel, move on to the various files, working the surface until it is again as smooth as possible.

Rub the piece with medium, then fine sandpaper. Repeat the process until 00 grit sandpaper has been achieved. You are now ready to polish.

Wipe the piece carefully with a cloth, removing any sandings from the surface.

There are two basic methods of polishing wood:

1. Beeswax polishing (hard woods)
 - a. Cut several pieces of beeswax and place them in a metal tin.
 - b. Cover the pieces with turpentine.
 - c. Float the tin in a saucepan of water and heat until the wax melts.
 - d. Allow the mixture to cool.
 - e. Apply the wax to the piece in thin coats and polish with a soft, clean cloth.
2. Lacquer coating (soft woods)
 - a. With a clean brush, flow on an even, thin coat of lacquer and allow to dry overnight.
 - b. Polish the surface with fine steel wool.
 - c. Repeat the process.
 - d. If the wood still does not have the desired luster, apply a coat of Butchers wax and polish.

Note: For additional information, techniques, etc., refer to quinmester course entitled Wooden Forms .

Work Sheet #2 - Modern Materials

Metal Sculpture - (Oxy-acetylene welding)

Oxy-acetylene welding is one of the most exciting sculpture processes available to the artist today. The process itself involves melting and joining metal with an intense flame (5000⁰ F+) consisting of compressed oxygen mixed with compressed acetylene.

- A. Oxy-acetylene equipment: The following equipment is necessary in the process of oxy-acetylene welding:
1. Oxygen and acetylene cylinders: These cylinders are under pressure (oxygen 2,000 lbs. p.s.i. - acetylene 250 lbs. p.s.i.) and should be treated with great care. Cylinders should be stored and used in a firmly secured, upright position.
 2. Regulators and gauges: This equipment is attached to the top of the cylinders. They consist of a shutoff valve to regulate flow, and two gauges per cylinder; one to indicate tank pressure and one to indicate flow pressure.

3. Gas hoses: These hoses run from the tanks to the torch, and carry the flow of gasses, (separately). They are color-coded (O₂-green/acetylene-red) and have indicator marks on the connecting nuts as further safety precautions.
4. Torch: The oxy-acetylene torch is a metal instrument which combines the two gasses for welding. There are pressure flow adjustment valves on the torch to regulate the flame (depending on the type and thickness of the metal to be welded). This is the tool that the artist actually holds in his hand and welds with. Torches come with interchangeable tips for various welding situations.
5. Goggles: Special goggles are used to protect the eyes from the flame when welding. Always wear them when working with the torch.
6. Protective clothing: It is advisable to wear hard-surface shop overalls. (Thin clothing may catch on fire.)

7. Gloves: Asbestos gloves are the most suitable protection for welding.
8. Sparker: (A small hand device that causes a spark to ignite the flame).

B. Procedure:

1. Setup:

- a. Read carefully the instructions on care of equipment (supplied with the equipment).
- b. Check that all hoses have been connected correctly.
- c. Open the regulator valve on the oxygen tank $1/2 - 3/4$ of one turn.
- d. Turn on the other oxygen regulator to between 5-10 16 lbs. pressure. (flow valve)
- e. Open valves on acetylene in the same manner.
- f. Open oxygen valve on torch and reset valve on tank to desired pressure.
- g. Do the same to the acetylene valve.

2. Torch operation:

- a. Open the acetylene valve on the torch $1/4$ turn and ignite the acetylene. This will cause a feathery yellow flame.

Continue to open the valve until the flame jumps slightly away from the tip.

- b. Gently, open the oxygen valve until the feathery flame disappears and a sharp, inner cone of flame forms. This is the correct flame for welding.

Note:

- (1) If the outer flame is still feathering, cut down on the acetylene.
 - (2) If the flame (inner cone) becomes small and there is a loud hissing, cut down on the oxygen.
3. Checking for leaks: It is a good practice to apply clean soapy water to all joints occasionally with a brush. Gas leaks will show up as bubbles.
4. The weld: Oxy-acetylene welding is a process that cannot be hurried. It, like any other form of sculpture, is an art and must be planned, controlled, and executed in an artistic manner. There are hundreds of interesting effects that can be achieved with oxy-acetylene welding, and the best way to learn is through experimentation. The technique consists of melting both edges of the

parent metals to one another. Hold the flame just above the surface of the metal, proceeding forward slowly at a 30 degrees angle. (This will also preheat the metal you are approaching). By using a small circular motion as you proceed, the metal will "puddle" under the flame and run together.

The speed at which you move the flame along is dictated by the type and thickness of the metal being welded. The toughest part is to control the puddling so that the metals melt and flow together rather than burn apart. Experimentation and practice is the rule.

In some cases you will need the use of a rod of filler metal to help join areas or fill holes. These rods come in many types and diameters. Use the reference materials to select the rod compatible with your work.

C. Common problems and solutions:

1. Flashback:
 - a. Shut off all valves
 - b. Clean the tip

- c. Check gas pressures and tip size
- 2. Brittle weld:
 - Improper gas mixture
- 3. Popping:
 - a. Wrong size tip
 - b. Incorrect pressure
 - c. Touching tip to metal
 - d. Clogged tip
- 4. Burning holes in the metal:
 - a. Holding flame in one place too long.
 - b. Too large a tip
 - c. Too much pressure

D. Oxy-acetylene cutting:

A special torch is used in cutting. It has several holes in the tip and a press-lever that introduces high pressure oxygen to the flame.

- 1. Preheat the metal to cherry-red color.
- 2. Holding the tip in a vertical position, depress the oxygen lever. (This will cause a shower of sparks from cutting, to appear on the opposite side), This indicates that correct cutting is taking place.

3. Pressures: Oxygen 30-70 p.s.i.
Acetylene 3-6 p.s.i.

Note: Take special fire precautions because of amount of heat and sparks.

Note: Special effects, patina, and other welding procedures are described in depth in a quinmester course of study entitled Metallic Formations I.

Work Sheet #3 - Modern Materials

Plaster Sculpture - Plaster is a medium that can be carved with relative ease. It may be left as is when completed, or it may be painted or varnished to achieve a high gloss. As a permanent sculptural medium it is not widely used by professional artists, but does make an excellent material for experimentation in form and texture for beginners.

A. Set up

1. Add water to the plaster, in a mixing container. Stir the mixture constantly, and stop adding water when the mixture reaches a consistency similar to heavy cream. (smooth).
2. Pour the mixture into a 1/2 gallon milk container and tap the sides. (This will cause air bubbles to rise to the surface).
3. Allow to set overnight.
4. Peel away milk container, and you are ready to carve.

B. Procedure:

Plaster may be carved with special plaster carving tools, or many household items such

as knives, files, chisels, etc. Use the same approach as in wood; carving from all sides and stepping back frequently to observe proportions.

Balloons may be taped to the inside of the milk carton before pouring in order to create hollow areas in the piece. This saves much carving time.

Vermiculite may also be added to the plaster - before water is introduced, to create a similar block which is much softer, easier to carve, and containing texture. This process might be suggested to female students as solid plaster carving requires considerable strength.

The finished piece may be left as is, spray painted, varnished, or antiqued with shoe polish. This step is up to the individual student.

C. Alternate Methods:

1. Another way in which plaster may be sculpted is by building up strips of cloth, soaked in plaster, onto an armature. Once the rough shape has been achieved, pure plaster may be applied with a putty knife.

2. Plaster may also be worked by soaking cloth in a solution of plaster and "draping" it over an armature. This creates interesting abstract forms.

Work Sheet #4 - Modern Materials

Styrofoam Sculpture - Styrofoam is a brand name of a Dow Chemical Company product. It is actually an expanded polystyrene emulsion. Styrofoam may be purchased in any of a number of assorted sizes and shapes, depending on what the sculptor had in mind.

A. Procedure:

1. Styrofoam may be cut and shaped quite easily with many common items, such as knives, coping saws, or soldering guns. One device which works very well is a hot-wire cutter. The directions for such a device, which can be made inexpensively, are as follows:

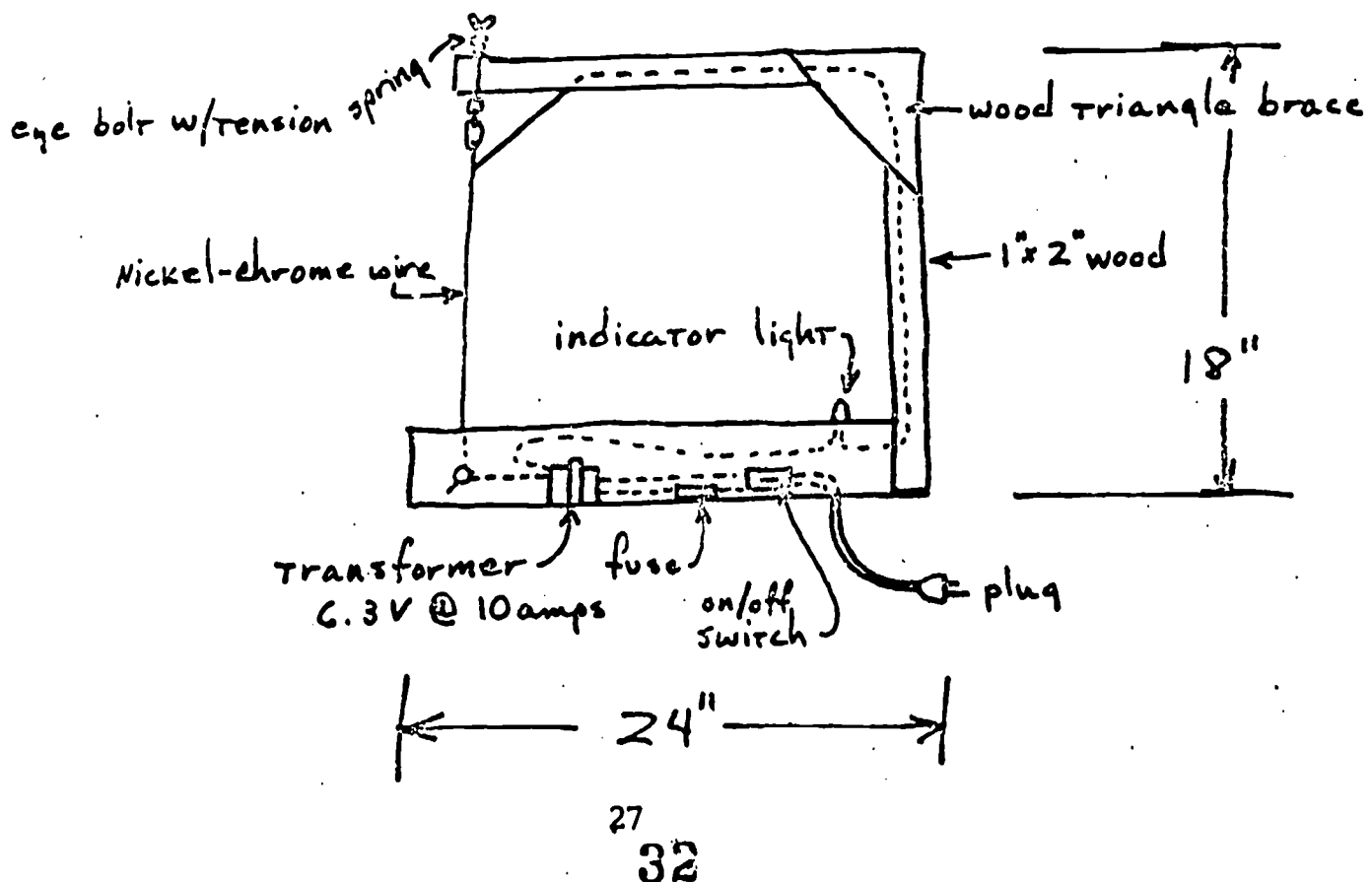

2. Styrofoam may be joined in many interesting ways:

- a. Toothpick "pins"
- b. Wire (sewn)
- c. Epoxy glue
- d. Asphalt adhesive
- e. Wire rods
- f. Wood dowels

- when using a glue, pretest a scrap piece, as many types of glue will not hold, or will dissolve the foam.

3. Styrofoam may be "textured" in many ways:

It can be sanded, melted, pinched, punctured, or "eaten away" at the surface by various solvents. Experimentation on test pieces is the best way to achieve the effect you want.

Water base paints are the best type for adding color, as many oil base paints contain solvents that will affect the texture you have created.

If you wish to use a finishing material that would dissolve the foam (lacquer, polyester coatings, etc.) it may be better

to use a urethane foam, which is resistant to many more chemicals.

Note: Do not use the hot wire-cutter on this type of foam however, as it gives off a poisonous gas when burned. Stick with coping saws, knives, etc.

Work Sheet #5 - Modern Materials

Plastic Sculpture - There are hundreds of different polyester resins and assorted materials available commercially today, and even as you read this there are more being created. It would take volumes to describe the various techniques and efforts that can be achieved with these products. Since this unit is introductory in nature, we will concern ourselves with one of the basic plastics and its sculptural qualities.

A. Acrylic Sheet - Acrylic Rod

Acrylic Sheet (commonly referred to as Plexiglas -- a Rohm and Haas Company brand name), is a thermo-plastic resin similar in appearance to regular glass. However, this is where the similarity ends. Acrylic sheet is much stronger (5-15 times as strong), and, when heated at relatively low temperatures, may be hand formed. Pound for pound, acrylic sheet weighs approximately half as much as glass. Common acrylic sheet is clear, but may also be obtained in a translucent, opaque, or textured form. It also comes in a wide variety of colors.

Sheer thickness varies in size between 1/16"

and 1". Rods are available from 1/16" to over 15" in diameter. (The larger the size, the more expensive the materials).

Acrylic sheet may be worked with most common shop tools; electric drills, coping saws, sandpaper, etc. An electric jig saw is the most efficient tool for cutting sheet.

Since acrylic sheet comes with protective paper on both sides (which should not be removed until all cutting has been done), it is very easy to draw the desired design or pattern right on the paper. A pattern may also be cut and glued to the protective paper if desired. You may then proceed to cut the sheet.

Once the pattern is cut out, peel off the protective paper. You are now ready to form. Acrylic sheet will soften at 250° F. This may be done in an oven, or over a burner (electric).

Using protective gloves, form the plastic into the desired shape and hold until cool.

B. Other technique

1. Joining:

Ethylene dichloride, when applied with a

brush or eye dropper to clean, acrylic sheet, will act as a strong bonding agent that dries clear. As ethylene dichloride is a solvent, care should be taken during application.

Epoxy cements will also act as bonding agents.

2. Melting:

Sagging effects may be achieved by increasing the temperature applied to the sheet. This, however, may cause bubbling (which in some cases might be desirable). Acrylic sheet will ignite when heated over 700⁰ F. This, also, may create some interesting effects. Experiment with scrap pieces.

3. Polishing:

There are three steps in polishing acrylic sheet:

- a. Buff with white tripoli compound
- b. Buff with white acrylic polish compound
- c. Buff with wax-polish (non abrasive)

This work sheet has been written to explain the physical characteristics of acrylic sheet and give some suggestions as to what can be done with it.

Experiment on scrap pieces to determine what method you prefer before you begin the sculpture. Perhaps you can develop another application to this medium. Do not limit yourself to the processes mentioned here.

Work Sheet #6 - Modern Materials

Fiberglass Sculpture - Fiberglass is basically synthetic glass fibers that have been saturated with a polymerized resin which hardens into a strong, durable material, (polymerization). It has unlimited forming capabilities and is stronger than any other material of a comparable weight.

A. Procedure:

1. One of the most important rules to observe when working with polyester resin is to have adequate ventilation. The resin has a strong odor that can cause you to feel ill.
2. The floor should be bare, smooth cement to facilitate cleanup. Spread newspapers as an added measure.
3. Work away from heat sources as the materials are flammable.
4. In working with polyester resin you have a certain working period before the added catalyst causes the resin to harden. Never mix more resin than you can use in that period of time. (The period of time is determined by the amount of catalyst (hardener added).

5. The most important step is to add the correct amount of catalyst. A general guide to follow is 10 drops of catalyst per ounce of resin. At 70 degrees F. this should give you about 30 minutes working time. This time can be shortened proportionately by adding more catalyst. Keep in mind that too much catalyst might cause such a rapid hardening process that the form will warp from the heat generated. The best way to determine how much hardener to use for your specific condition is to make the first batch as described above, then adjust to make the desired rate of cure in later batches.

B. Armature Construction :

1. An armature is a beginning shape or form onto which the fiberglass will be applied. Some materials suitable for fiberglass armatures:
 - a. Chicken wire, or wire mesh
 - b. Crumpled newspaper held together with string, glue, or tape.
 - c. Metal (coat hanger wire)
 - d. Wood (dowels, strips, blocks)

e. Papier mache

f. Cardboard

2. Once the armature is built and the resin is prepared, you may either dip the fiberglass cloth into the resin and then drape it over the armature, or wrap the cloth on dry and then saturate it with a brush. Work carefully, yet plan your time according to the pot life of the resin.
3. Once the mixture begins to cure or set, clean the brush in acetone. You may then start another batch in a clean mixing can.
4. Fiberglass, when partially cured (leather hard) may be cut or trimmed with a sharp knife. When it cures fully, you will need the aid of a hacksaw, coping saw, drill, or sabre saw to penetrate the glass.
5. Build-up may be done more rapidly with fiberglass mat, which comes in varying thicknesses, and also may be chopped up. Mat also increases the strength of the piece and has its own unique texture. Other fillers such as sawdust, powdered metals, newspaper, etc., may also be mixed with or laminated on with resin.

C. Texture and Finishing:

Fiberglass may be left as is if that is the artist's choice, but there are many finishing effects that may be created:

1. Texture may be added by combining resin with any filler, (grease and oil free) and painting the mixture on (sand, sawdust, metal filings, etc.).
2. Rope, cord, string, or yarn applied to the surface.
3. Saturated cloth (burlap, linen, etc.)
4. Chopped fiberglass
5. Fiberglass mat

You may also achieve a highly polished surface by smoothing with files, sandpaper (coarse to 00 grit) and wax.

Fiberglass may also be painted (using epoxy resin paints).

Fiberglass is a highly versatile medium. Experiment with it. Find out what you can do. You may be surprised with the results. There are artists today who work exclusively in fiberglass, because of its versatility. It is one of the only media that can be made to look like almost any other.

Work Sheet #7 - Modern Materials

Base Design and Creation:

Most sculpture is created either freestanding, or mounted on a separate base. If your sculpture is of the second type, here are some guidelines to follow:

A. Design:

A base should be designed to complement the sculpture for which it is made. The design should be simple and direct. Keep in mind that the base should not detract from the visual impact of the sculpture itself.

Some sculptors have a base in mind as early as when they are still creating the sculpture. However, the artist must remember that the base is designed to fit the sculpture; not the other way around.

Simplicity is a key word in the design of a good base.

B. Media Compatibility

The next step in creating a base is to select the material from which it is made.

Basically, it is a matter of individual taste as to which material should be selected. As you

have already created a design, you are now concerned with the color and texture of the material. For example, marble is generally available in green, pink, or cream color; wood in varying shades of brown; metal, is brown, silver, grey, etc. In this way, certain materials in their natural state will apply themselves well to the piece. Metal bases might be painted any one of a number of colors.

Do not limit yourself to finished materials alone. Experiment with coarse or unfinished surfaces. You may find that the sculpture-base texture conflict may work well.

C. Mounting:

Most sculpture is mounted directly on, or in a raised position above a base. (Some sculpture is suspended from a ceiling). Epoxy glue is usually the best means of attaching a piece to the base, directly, or mounted on wood or steel dowels, in an elevated position.

IX. VOCABULARY *

1. Acetylene - a gas used in conjunction with air or pure oxygen to weld metal.
2. Alloy - a secondary metal composed by the permanent fusion of two or more primary metals.
3. Armature - a framework built as a support for plaster, or fiberglass sculpture application.
4. Asbestos - a heat resistant substance used in welding for protection.
5. Base metal - the piece of metal being cut or welded.
6. Bench clamp - a large clamp used to hold a piece of wood to a bench for carving.
7. Catalyst - (hardener) a liquid used in plastics to cause the liquid plastic or resin to "set" (become hard).
8. Chisel - a sharp edged tool, available in various sizes and shapes, used for carving wood.
9. Closed form - A form, solid in appearance; having no holes or cavities, a form that encloses space.
10. Cure - (set) the resulting condition of a plastic after chemical alteration.

11. Direct carving - a process by which a subject is sculpted from a solid block or form of media by cutting in from the surface.
12. Draping - the process by which material or cloth is soaked in a liquid, then hung or wrapped onto an armature and allowed to set.
13. Feather - a yellow, outer flame caused by an excess of acetylene in the mixture.
14. Flux - a compound used in welding to burn off oxides from the surface of the metal to be joined.
15. Fusion - the complete and permanent joining of two materials.
16. Gel - a jelly-like condition of a resin before curing.
17. Gel coat - a thin layer of gel, usually applied to the surface of a piece to add color.
18. Gouge - a chisel having a u-shaped edge, used primarily for creating curved surfaces.
19. Gouge slip - a sharpening stone for gouges that is curved to match the gouge blade.

20. Hot wire cutter - an instrument used to cut styrofoam by searing with a heated wire that is under tension.
21. Inhibitors - agents or additives used to retard the setting process of plastics or resins.
22. Laminate - to form a single layer of material by building up several thinner layers and allowing them to bond together.
23. Lay up - to apply or build up layers of materials on an armature or form.
24. Mallet - an instrument similar to a hammer, used to strike a chisel for carving.
25. Media - any material used in the construction of sculpture.
26. Open form - a form containing hollow areas or cavities (as opposed to closed forms).
27. Pass - the resultant metal left on a weld that has been created.
28. Plaster - a composition of lime, sand, and water.
29. Plate - metal that is more than 1/8" in thickness.
30. Plasticity - the ability to be bent twisted and shaped.

31. Pot life - the length of time in which a resin remains workable once the catalyst or hardener has been added.
32. Resin - a synthetic (in the case of fiberglass) substance, in liquid state, used in fiberglass construction as a bonding agent.
33. Riffler file - a file similar to a rasp, only having a smaller working area, used generally for detail work.
34. Rod - a length of metal used as a filler in welding.
35. Sculpture - plastic or hard materials that have been welded, molded, carved, engraved or constructed into a primarily three-dimensional work of art.
36. Sculpture - one who sculpts, or creates sculpture.
37. Sheet Metal - metal less than 1/8" in thickness.
38. Solvent - a substance that will dissolve another substance.
39. Set - to cure, or harden.
40. Studio - any area designed for, or in which artistic creation takes place.
41. Styrofoam - (trade name - Don Chemical) a polystyrene product that has been expanded and is extremely light and bouyant.

42. Texture - the structure of the surface of any work of art.
43. Tip - the head of a torch, from which the flame appears. (removable)
44. Tooling - working the surface of a sculpture to create texture.
45. Vermiculite - an insulation material added to plaster, making it easier to carve.
46. Welding - the process by which two pieces of metal are reduced to their melting points and are fused directly to each other.

* Definitions, in some instances, composed with the aid of the American College Dictionary, Random House, 1967 edit.

X. RESOURCES

A. Books

*Baldwin, J., Contemporary Sculpture Techniques, New York: Reinhold Publishing Co.

Craven, Wayne, Sculpture in America, Crowell, 1968.

Di Valentin, Mario, Sculpture for Beginners, Sterling Press, 1965.

Graham, F. D., Welders Guide, Bobbs Merrill.

Irving, D., Sculpture: Materials and Processes, New York: Van Nostrand-Reinhold.

*Meilach and Seiden, Direct Metal Sculpture, New York: Crow Publishing Co.

Mills, John W., The Technique of Sculpture, New York: Reinhold, 1967.

*Reed, H., History of Modern Sculpture, Praeger, 1964.

*Rood, John, Sculpture in Wood, University of Minnesota Press, 1950.

Rood, John, Sculpture with a Torch, University of Minnesota Press, 1956.

*Roukes, N., Sculpture in Plastics, New York: Watson-Guptill.

Stevens, Harold, Art in the Round, New York: Reinhold, 1965.

Note: It is suggested that resources marked with an asterisk be kept on hand in the classroom.

B. Movies, films, slides - (Available through Dade Co. Audio-Visual Services)

Discovering Texture

17'C

EJS

FAC

1-11659

Oxy-Acetylene Welding: Light Metal
21^oBW JS EBCC 1-13093

Resistance Welding
12^oBW JS Almanac 1-04071

20th Century Sculpture
C JST 1-20159

Making Wood Sculpture with Files
13^oC EJ Three Rivers 1-11649

Sculptor Carves a Giant: The
16^oC JS Three Rivers 1-11650